

90° & 180° DİRSEK KISA RADIUS



ASME B 16.28
STD - SCH X.S. - X.X.S.



E.M.P.
www.emp.com.tr
www.empflans.com

90° & 180° ELBOW SHORT RADIUS



ASME B 16.28
STD - SCH X.S. - X.X.S.

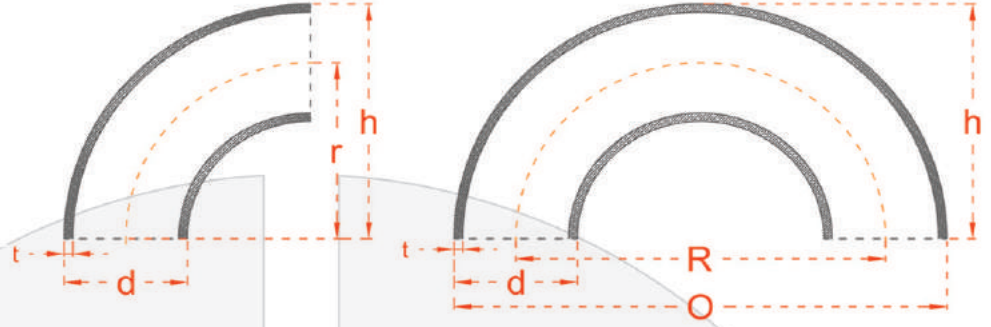

DN	INCH	DIŞ ÇAP	YÜKSEKLİK	90° RADIUS	180° RADIUS	180°	STD		SCH X.S.		SCH X.X.S.	
		DİAMETER	HEIGHT	90° RADIUS	180° RADIUS	DIŞTAN DIŞA	t	kg	t	kg	t	kg
		d	h	r	R	O						
25	1"	33	41.5	25	50	83	3.38	0.10	4.55	0.13	9.09	0.23
32	1 1/4"	42	53.0	32	64	106	3.56	0.16	4.85	0.23	9.70	0.41
40	1 1/2"	48	62.0	38	76	124	3.68	0.24	5.08	0.30	10.16	0.60
50	2"	60	81.0	51	102	162	3.91	0.43	5.54	0.6	11.07	1.13
65	2 1/2"	73	100.5	64	128	201	5.16	0.82	7.01	1.15	14.02	2.03
80	3"	89	120.5	76	152	241	5.49	1.35	7.62	1.85	15.24	3.47
	3 1/2"	102	140.0	89	178	280	5.74	1.90	8.08	2.6	x	x
100	4"	114	159.0	102	204	318	6.02	2.60	8.56	3.55	17.12	6.86
125	5"	141	197.5	127	254	395	6.55	4.35	9.52	6.20	19.05	12.02
150	6"	168	236.0	152	304	472	7.11	6.45	11.0	10.2	21.95	19.9
200	8"	219	312.5	203	406	625	8.18	16.5	12.7	22.5	22.23	36.12
250	10"	273	390.5	254	508	781	9.27	31.15	12.7	31.2	25.40	64.94
300	12"	324	467.0	305	610	934	9.52	45.00	12.7	49.0	25.40	93.91
350	14"	356	534.0	356	712	1068	9.52	52.50	12.7	63.1	x	x
400	16"	406	609.0	406	812	1218	9.52	71.25	12.7	82.6	x	x
450	18"	457	685.5	457	914	1371	9.52	90.00	12.7	104.9	x	x
500	20"	508	762.0	508	1016	1524	9.52	110.0	12.7	129.5	x	x
550	22"	559	838.5	559	1118	1677	9.52	132.0	12.7	157.0	x	x
600	24"	610	915.0	610	1220	1830	9.52	165.0	12.7	188.0	x	x

Ölçüler mm olarak verilmiştir.
Çelik ve paslanmaz üretilebilir.

Dimensions are in mm.
Steel and stainless steel can be produce

90° & 180° DİRSEK KISA RADIUS



ASME B 16.28
SCH 10 - 20 - 30



E.M.P.
www.emp.com.tr
www.empflans.com

90° & 180° ELBOW SHORT RADIUS



ASME B 16.28
SCH 10 - 20 - 30

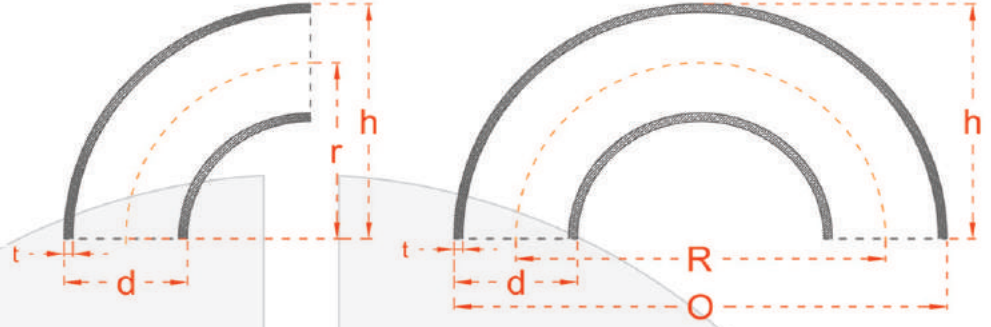

DN	INCH	DIŞ ÇAP	YÜKSEKLİK	90° RADIUS	180° RADIUS	180°	SCH		SCH		SCH	
		DİAMETER	HEIGHT	90° RADIUS	180° RADIUS	DIŞTAN	10	20	30			
		d	h	r	R	O	t	kg	t	kg	t	kg
25	1"	33	41.5	25	50	83	x	x	x	x	2.90	x
32	1 1/4"	42	53.0	32	64	106	x	x	x	x	2.97	x
40	1 1/2"	48	62.0	38	76	124	x	x	x	x	3.18	x
50	2"	60	81.0	51	102	162	x	x	x	x	3.18	x
65	2 1/2"	73	100.5	64	128	201	x	x	x	x	4.78	x
80	3"	89	120.5	76	152	241	x	x	x	x	4.78	x
	3 1/2"	102	140.0	89	178	280	x	x	x	x	4.78	x
100	4"	114	159.0	102	204	318	x	x	x	x	4.78	x
125	5"	141	197.5	127	254	395	x	x	x	x	X	x
150	6"	168	236.0	152	304	472	x	x	x	x	X	x
200	8"	219	312.5	203	406	625	x	x	6.35	11.1	7.03	12.26
250	10"	273	390.5	254	508	781	x	x	6.35	17.35	7.80	21.25
300	12"	324	467.0	305	610	934	x	x	6.35	25.0	8.38	32.78
350	14"	356	534.0	356	712	1068	6.35	30.5	7.92	39.5	9.52	52.50
400	16"	406	609.0	406	812	1218	6.35	39.0	7.92	52.2	9.52	71.25
450	18"	457	685.5	457	914	1371	6.35	48.5	7.92	65.35	11.13	93.07
500	20"	508	762.0	508	1016	1524	6.35	67.5	9.52	110	12.70	130
550	22"	559	838.5	559	1118	1677	6.35	84.5	9.52	132	12.70	172
600	24"	610	915.0	610	1220	1830	6.35	96.5	9.52	165	14.27	213

Ölçüler mm olarak verilmiştir.
Çelik ve paslanmaz üretilebilir.

Dimensions are in mm.
Steel and stainless steel can be produce

90° & 180° DİRSEK KISA RADIUS



ASME B 16.28
SCH 40 - 60 - 80



E.M.P.
www.emp.com.tr
www.empflans.com

90° & 180° ELBOW SHORT RADIUS



ASME B 16.28
SCH 40 - 60 - 80

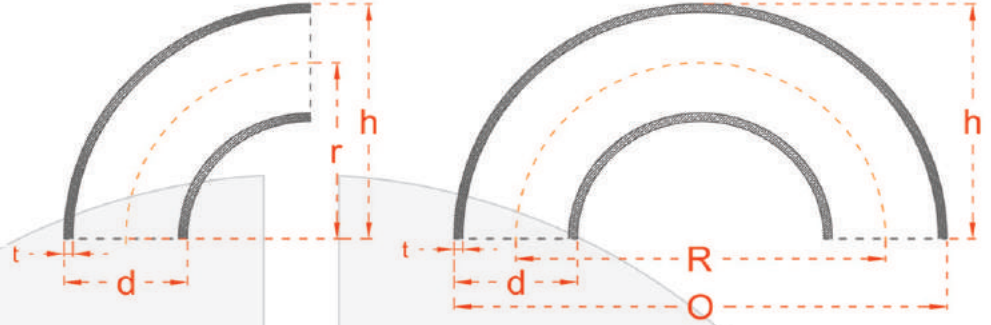

DN	INCH	DIŞ ÇAP	YÜKSEKLİK	90° RADIUS	180° RADIUS	180°	SCH		SCH		SCH	
		DİAMETER	HEIGHT	90° RADIUS	180° RADIUS	DIŞTAN DIŞA	40	60	80	80	80	
		d	h	r	R	O	t	kg	t	kg	t	kg
25	1"	33	41.5	25	50	83	3.38	0.10	x	x	4.55	0.13
32	1 1/4"	42	53.0	32	64	106	3.56	0.16	x	x	4.85	0.23
40	1 1/2"	48	62.0	38	76	124	3.68	0.24	x	x	5.08	0.30
50	2"	60	81.0	51	102	162	3.91	0.43	x	x	5.54	0.60
65	2 1/2"	73	100.5	64	128	201	5.16	0.82	x	x	7.01	1.15
80	3"	89	120.5	76	152	241	5.49	1.35	x	x	7.62	1.85
	3 1/2"	102	140.0	89	178	280	5.74	1.90	x	x	8.08	2.60
100	4"	114	159.0	102	204	318	6.02	2.60	x	x	8.56	3.55
125	5"	141	197.5	127	254	395	6.55	4.35	x	x	9.52	6.20
150	6"	168	236.0	152	304	472	7.11	6.45	x	x	10.97	10.2
200	8"	219	312.5	203	406	625	8.18	16.5	10.31	17.8	12.70	22.5
250	10"	273	390.5	254	508	781	9.27	31.2	12.70	31.15	15.09	40.0
300	12"	324	467.0	305	610	934	10.31	40.0	14.22	54.9	17.48	66.3
350	14"	356	534.0	356	712	1068	11.12	55.4	15.09	74.0	19.05	93.1
400	16"	406	609.0	406	812	1218	12.70	82.6	16.66	107	21.44	136
450	18"	457	685.5	457	914	1371	14.27	118	19.05	154	23.83	192
500	20"	508	762.0	508	1016	1524	15.09	153	20.62	207	26.18	260
550	22"	559	838.5	559	1118	1677	17.48	x	22.22	282	28.58	351
600	24"	610	915.0	610	1220	1830	17.48	256	24.61	355	30.96	444

Ölçüler mm olarak verilmiştir.
Çelik ve paslanmaz üretilebilir.

Dimensions are in mm.
Steel and stainless steel can be produce