

REDÜKSİYON KONSANTRİK & EKSANTRİK

REDUCER CONCENTRIC & ECCENTRIC



DIN 2616

DIN 2616

E.M.P.
www.emp.com.tr
www.empflans.com

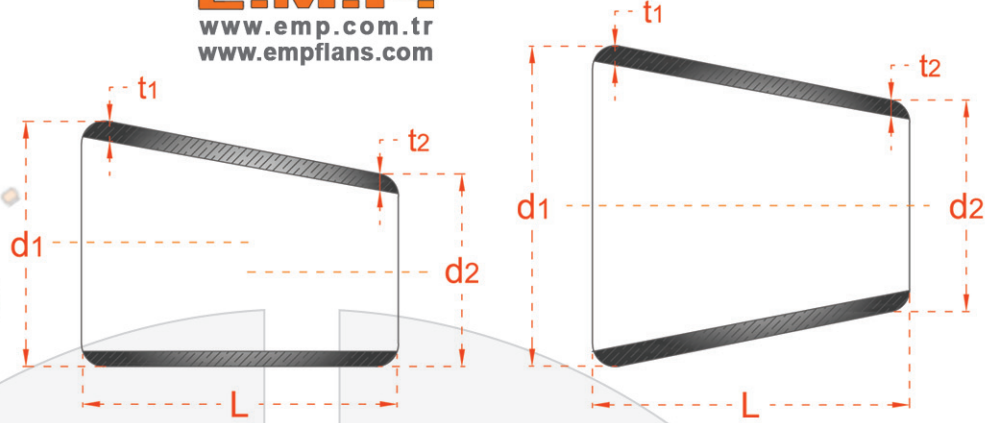

DN	DIŞ ÇAP DIAMETER d 1	ET KALINLIĞI WALL THICKNESS t 1			DIŞ ÇAP DIAMETER d 2	ET KALINLIĞI WALL THICKNESS t 2			L	SCH 40 ORTALAMA AĞIRLIK APPROX WEIGHT
		SCH 20	SCH 40	SCH 80		SCH 20	SCH 40	SCH 80		
250	273	6.0	8.0	10	219.1	5.9	8.0	12.5	178	6.6
					168.3	4.5	7.1	11.0		5.9
					139.7	4.0	7.1	10.0		5.5
300	323.9	6.0	8.0	10	273	6.3	10	12.5	200	9
					219.1	5.9	8.0	12.5		8.2
					168.3	4.6	7.1	11.0		7.5
350	355.6	6.0	8.0	10	323.9	6.0	8.0	10	330	16.9
					273					15.6
					219.1					14.2
400	406.4	6.0	8.0	10	355.6	6.0	8.0	10	355	20.4
					323.9					19.5
					273					18.1
450	457.2	6.0	8.0	10	219.1	6.0	8.0	10	381	16.7
					406.4					24.7
					355.6					23.3
500	508	6.0	8.0	10	323.9	6.0	8.0	10	508	22.4
					273					21
					219.1					19.4
550	558.8	6.0	8.0	10	457.2	6.0	8.0	10	508	36.95
					406.4					35
					355.6					33
600	609	6.0	8.0	10	323.9	6.0	8.0	10	508	31.8
					273					30
					219.1					27.8
650	662	6.0	8.0	10	508	6.0	8.0	10	610	41
					457.2					39
					406.4					37.7
600	609	6.0	8.0	10	558.8	6.0	8.0	10	508	44
					508					42.8
					457.2					40.8
650	662	6.0	8.0	10	406.4	6.0	8.0	10	610	38.9
					355.6					37
					323.9					35.7
600	609	6.0	8.0	10	273	6.0	8.0	10	610	33.8
					219.1					31.7
					168.3					29.6
650	662	6.0	8.0	10	609	6.0	8.0	10	610	58
					558.8					56.2
					508					53.8
600	609	6.0	8.0	10	457.2	6.0	8.0	10	610	51.4
					406.4					49
					355.6					46.7
650	662	6.0	8.0	10	323.9	6.0	8.0	10	610	45.3
					273					43
					219.1					41

Ölçüler mm olarak verilmiştir.
Çelik ve paslanmaz üretilir.

Dimensions are in mm.
Steel and stainless steel can produce.

TS EN 10217 - 1 ET KALINLIKLARINDAN İMALATÇI TERCİHİ KALINLIKLAR SEÇİLMİŞTİR. (DN 250 DAHİL ÜSTÜ ÖLÇÜLERDE)